

VSP-122P

MAIN STATION - BATTERYLESS TELEPHONE SYSTEM - 12-WAY



when communication is **critical**

FEATURES

- Portable substation
- 12 extensions selector
- Waterproof housing
- Carry handle and 5 meter cable with 16-pin Amphenol plug
- Used together with CD-16 at bridge wings and open deck areas



SPECIFICATIONS

Connections	CD-16 Plug box
Housing	ROSE Box (AISI12)
Handset	RA-250 w/ holder
Colour	Grey RAL7001 / Handset black
IP rating	IP-66
Weight	2.6 kg
Dimensions (WxHxD)	220 x 220 x 185 mm (with handset)

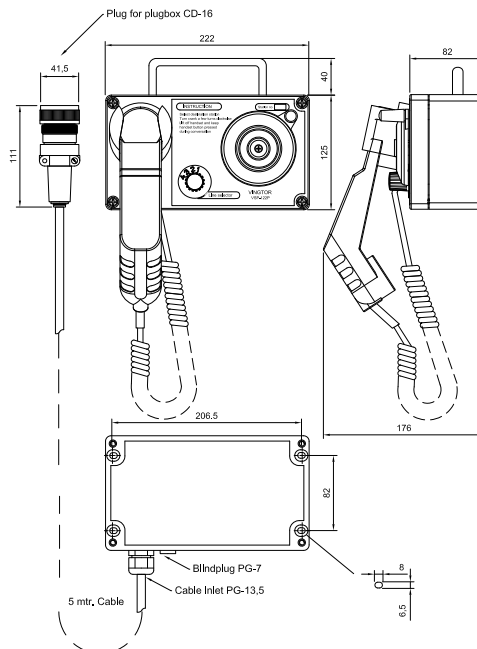

ORDER NUMBER	DESCRIPTION	SHIP WEIGHT
3006200024	VSP-122P Main Station, Portable, Batteryless Telephone System - 12-way	2.6 kg
Related items: 1020600982	CD-16 Plugbox for VSP-122P IP-66	0.6 kg

ORDER NUMBER

3006200024

DOC NO

A100K10433

02.11.2012

sales@vingtor.com



Zenitel and its subsidiaries assume no responsibility for any errors that may appear in this publication, or for damages arising from the information therein. STENTOFON and VINGTOR products are developed and marketed by Zenitel. The company's Quality Assurance System is certified to meet the requirements in NS-EN ISO 9001. Zenitel reserves the right to modify designs and alter specifications without notice. ZENITEL PROPRIETARY. This document and its supplementing elements, contain Zenitel or third party information which is proprietary and confidential. Any disclosure, copying, distribution or use is prohibited, if not otherwise explicitly agreed in writing with Zenitel. Any authorized reproduction, in part or in whole, must include this legend. Zenitel - All rights reserved.