

VSP-213-L

MAIN STATION - BATTERYLESS TELEPHONE SYSTEM - 12-WAY



when communication is **critical**

FEATURES

- 12 extensions selector switch
- Flush mounted
- Wall mounting with corresponding metal cabinet type MBOKS
- Desk mounting with corresponding wooden cabinet type VSPK
- Suitable for installation in wheelhouse, control room or accommodation.

SPECIFICATIONS



Connections	Screw terminals
Colour	Black
IP rating	IP-44
Dimensions (WxHxD)	238 x 205 x 137 mm (w/ handset and built-in depth)
Panel cut-out	205 x 105 mm
Weight	1.3 kg

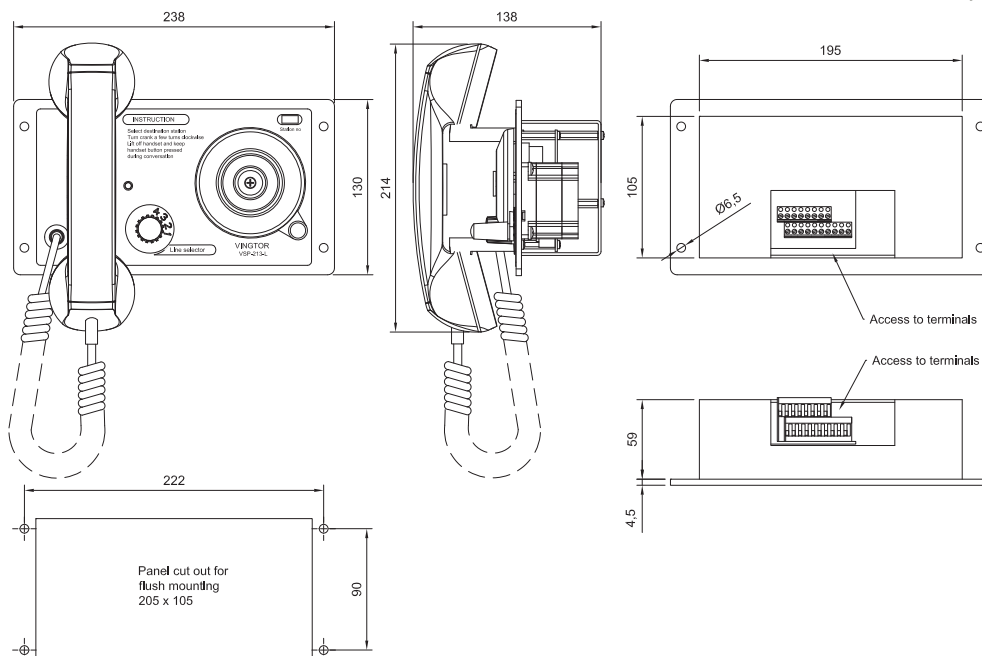

ORDER NUMBER	DESCRIPTION	SHIP WEIGHT
1020600935	VSP-213-L Panel Mounted Indoor Unit Batteryless Telephone System - 12-way	1.30 kg
Related items:		
3006090478	MBOKS Metal Box for Wall Mounting	1.0 kg
3006200049	VSPK Wooden Cabinet for Wall Mounting incl. Inserts	0.55 kg

ORDER NUMBER

1020600935

DOC NO

A100K10431 v.6

13.7.2011

www.vingtor.com - sales@vingtor.com



VINGTOR products are developed and marketed by Zenitel Norway AS. The company's Quality Assurance System is certified to meet the requirements in NS-EN ISO 9001:2008. Zenitel Norway AS reserves the right to modify designs and alter specifications without prior notice, in pursuance of a policy of continuous improvement. © 2011 Zenitel Norway AS.