

VSP-211-L

MAIN STATION - BATTERYLESS TELEPHONE SYSTEM - 12-WAY



when communication is **critical**

FEATURES

- 12 extensions selector switch
- Equipped with the built-in system amplifier w/capacitor battery
- Terminals for auxiliary 24VDC when used as Common Battery Telephones. To avoid noise problems, the 24VDC must be supplied via a DC / DC converter
- Flush mounted
- Wall mounting with corresponding metal cabinet type MBOKS
- Desk mounting with corresponding wooden cabinet type VSPK
- Suitable for installation in wheelhouse or control room



SPECIFICATIONS

Connections	Screw terminals Color
Color	Black
IP rating	IP-44 (in console)
Dimensions (WxHxD)	238 x 205 x 137 mm (w/ handset and built-in depth)
Panel cut-out	205 x 105 mm
Weight	1.30 kg

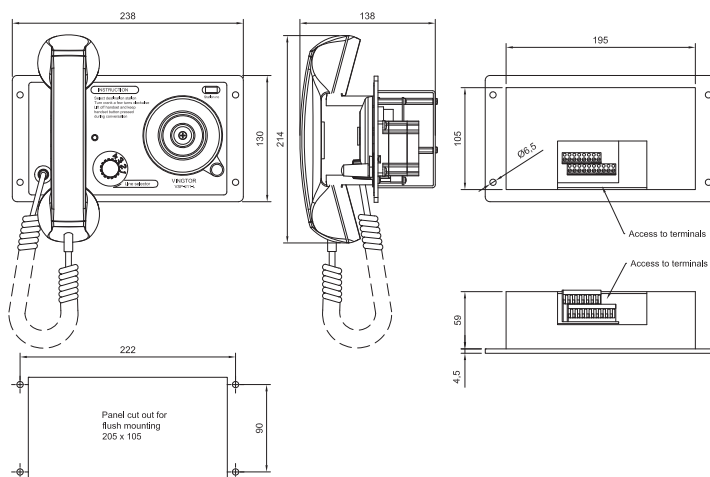

ORDER NUMBER	DESCRIPTION	SHIP WEIGHT
1020600931	VSP-211-L Main Station, Panel Mounted Battery Telephone System - 12-way	1.30 kg
Related items:		
3006090478	MBOKS Metal Box for Wall Mounting	1.0 kg
3006200049	VSP Wooden Cabinet for Wall Mounting incl. Inserts	0.55 kg

ORDER NUMBER

1020600931

DOC NO

A100K10424

31.10.2012

www.vingtor.com - sales@vingtor.com



Zenitel and its subsidiaries assume no responsibility for any errors that may appear in this publication, or for damages arising from the information therein. STENTOFON and VINGTOR products are developed and marketed by Zenitel. The company's Quality Assurance System is certified to meet the requirements in NS-EN ISO 9001. Zenitel reserves the right to modify designs and alter specifications without notice.

ZENITEL PROPRIETARY. This document and its supplementing elements, contain Zenitel or third party information which is proprietary and confidential. Any disclosure, copying, distribution or use is prohibited, if not otherwise explicitly agreed in writing with Zenitel. Any authorized reproduction, in part or in whole, must include this legend. Zenitel - All rights reserved.